

# PT-50/T PT-25/T

## LINEAR MOTION POSITION SENSOR

The Mini position trasducer is designed for direct absolute measurement and available in stroke lenght up to 50 mm. The mini design is suitable for mounting in instruments or machines with limited space.

An improved technique for making connection to resistance track (Double Trimming Technique) ensures the higher degrees of reliability and linearity, while multi-fingers wipers stabilize output signals, even in the most adverse working conditions.

The fixing feet are adjustable to the deisired positions.

### Features

- Harden steel ball head for measurement of cam following applications
- Mini design for limited space
- Anodised aluminium housing
- Double slide and bearing
- Very long life > 100 x 10<sup>6</sup> Cycles > 25 x 10<sup>6</sup> m
- Outstanding linearity up to : ± 0.1%
- High resolution : infinite
- Excellent repeatability : ±0.01 mm
- Max operating speed : 5 m/s max.
- PT-50/T : 4 pin C193 connector
- Sealing IP 40 standard (IP 65 optional)
- Operating temperature : ~ 30 ~ 100°C
- Storage temperature : ~ 50 ~ 120°C

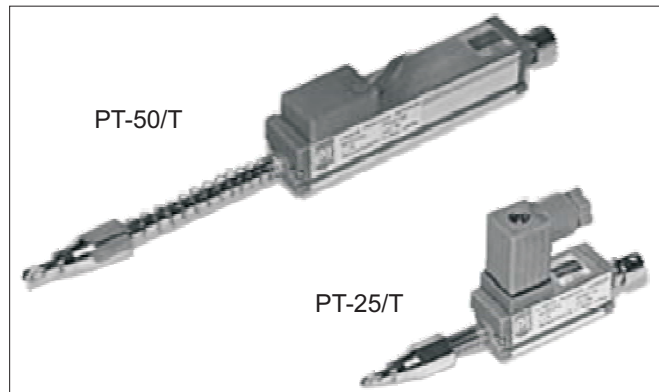

### Technical Specifications

- Current Resistance ≤ 10mA
- Wiper ≤ 1mA
- Operating force ≤ 1.2N (IP40) ≤ 5N (IP 65)
- Power consumption 3W-10W
- Output smoothness <± 0.1% against input voltage
- Input voltage 60 V Max
- Insulation Voltage 500V-1 min Residue <5 µA
- Vibration IEC 68-2-6: 1982 10g
- Shock IEC 68-2-29: 1968 40g

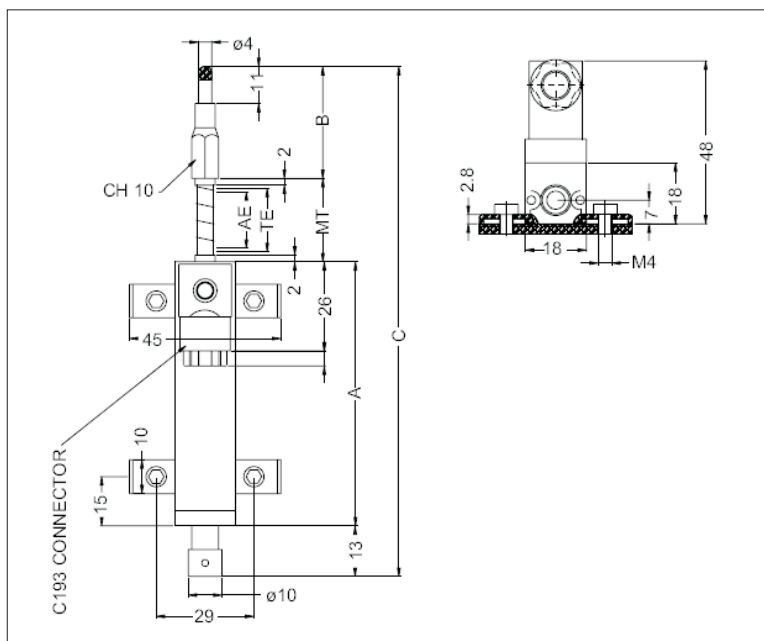

PT/T Series		25	50
Total Electrical Travel (T.E.)	mm	26	51
Active Eelectrical Travel (A.E)	mm	25	50
Resistance ±20%	KΩ	1	6
Independent linearity	±%	0,2	0,1
Mechanical Travel (M.T.)	mm	30	55
Resolution		inf.	inf.
Recommended Cursor Current	µ A	<1	<1
Temperature Range	°C	-30to+100	
Dimensions (A)	mm	63	88
Dimensions (B)	mm	32	40
Dimensions ©	mm	138	196

### ELECTRICAL CONNECTIONS

